



Energy International Systems Ltd.

***Using renewable technologies for
powering the DG snow maker***

Mr. F. Best, Technical Director
5th November 2010

ENERGY REQUIREMENTS OF SNOW PRODUCING DEVICES



500 kg/m³ snow

Conversion from water to ice: Energy obtained from the environment – *FREE*

Compressor, fans etc.: Energy required typically 0.5 kWh/m³ machine made snow (balls of ice, UNESCO Snow Classification)

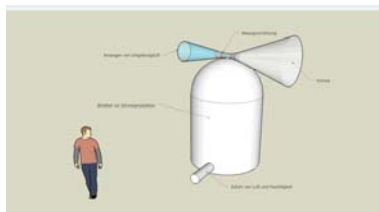

200 kg/m³ snow

Conversion from water to ice: Energy obtained from the environment – *FREE*

Pumps, fans etc.: Energy required typically 0.1 kWh/m³ snow

HOW CAN WE PRODUCE THE ENERGY NEEDED FROM RENEWABLE SOURCES

1. Wind

- a) direct drive (old windmill type technology)
- b) turbine (conversion to electricity)
- c) electrical and mechanical energy will require storage media

2. Solar (photovoltaic)

- a) direct conversion to electricity
- b) electrical energy will require storage media

3. Solar (thermal)

- a) direct conversion to thermal energy
- b) thermal energy will require storage media
- c) thermal energy can be converted into mechanical, electrical energy plus heating and cooling should this be necessary

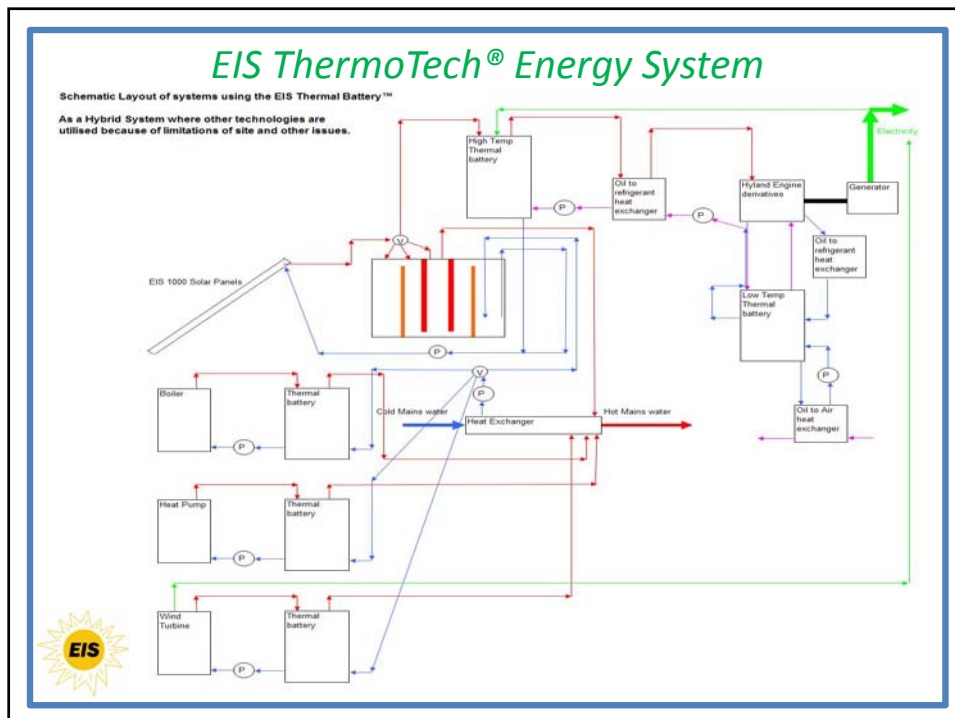



Energy
International
Systems
Group Ltd

EIS 500 Vacuum Super Insulation (VSI)

EIS 500 Vacuum Super Insulation – Key Features

- A thermal insulation panel which lets virtually no heat to pass through it.
- The product has a patented edge that helps to improve the overall efficiency.
- It is both very light and very strong.
- It is much thinner than other forms of insulation.
- It is highly cost effective and has a useful life expectancy of more than 100 years.



Energy
International
Systems
Group Ltd

EIS 500 Vacuum Super Insulation (VSI)

EIS 500 Vacuum Super Insulation – Key Benefits

- It keeps things warm
- It keeps things cold too
- In summary it can contain thermal energy and prevent it escaping from or intruding into a temperature controlled environment
- In general it saves energy
- It considerably reduces CO₂ production wherever it is used



Energy
International
Systems
Group Ltd

EIS 500 Vacuum Super Insulation (VSI)

EIS 500 Vacuum Super Insulation – Potential Applications

- Heat Battery or thermal energy store – This product allows large amounts of thermal energy to be stored in a relatively small space. For example a unit the same size as a bedside cabinet could store enough thermal energy for a typical UK house for up to 5 days.
- Cladding for Buildings – VSI panels can be used like an overcoat for existing buildings which would greatly enhance their energy efficiency
- Forward bases for military operations – field hospitals and accommodation
- Temporary housing in disaster areas – again the panels are both light and strong and would be suitable for transportation



Energy
International
Systems
Group Ltd

EIS Technologies - A new perspective on renewable energy generation and application...

- ***EIS ThermoTech® Thermal Battery***
- ***EIS 1000 Solar Thermal Panel***
- ***EIS 500 Vacuum Super Insulation (VSI)***
- ***EIS SolMax® Special Coating***
- ***EIS ThermoTech® Solar Thermal Desalination Unit***
- ***EIS ThermoTech® Dendritic Generator***
- ***EIS ThermoTech® Non-Electric Air Conditioning Unit***
- ***EIS ThermoTech® Energy System***



SUPER
VSI
SuperLine Ltd.

The EIS 2000 Super Solar Panel was developed at The University of Wales, Cardiff. This photograph, taken at the Heliodon facility, shows a prototype panel rig being tested.

